

## FEA Simulation Vibration of Head Gimbals Assembly

*Presented in 1<sup>st</sup> Data Storage Technology Conference (DST-CON 2008)*

*Tawin Phonpai and Thira Jearsiripongkul\**

---

### Abstract

In this paper, an analysis of vibration of head gimbals assembly (HGA) in hard disk drive (HDD) with operational HDD are studied. ANSYS is used for the finite element (FE) modeling and simulation. The FE model is verified by conducting a modal analysis of HGA. Resonant frequencies are compared with the Modal testing from Scanning Laser Doppler Vibrometer (LDV) results. The results of the natural frequencies and mode shape from both finite elements analysis (FEA) and SLDV show a good agreement and this information can also be used to further study the vibrations of Head Stack Assembly (HSA) and to develop the finite element model of HGA.

**Keywords:** HGA, FEA, Modal analysis.

### Introduction

Hard disk drive (HDD) are the most useful external storage devices for computer systems and consumer electronic equipment. Digital information is recorded in concentric tracks on rotating disks using miniaturized read/write (R/W) elements in an HDD. R/W elements are mounted on self-lubricated sub micrometer flying sliders. These sliders are connected to stainless steel (SST) suspensions that are connected to guide actuator arms and a voice coil motor (VCM) which allows cross-track seeking and track following of R/W elements. A head gimbal assembly (HGA) consists of the slider and the SST suspension. The recording density of HDDs increases several tenths of a percent every year. However, the airflow-induced vibration of an HGA windage is an

obstacle to increasing track densities in HDD. (Shigeo Nakamura et al., 2005) Our earlier finite element analysis studies have shown natural frequencies and mode shape comparable with experimental .

The strategy of the present study technique in predicts results of vibration by finite element analysis. Which this research aerodynamic force in HDD that happen be force the source does with HGA while flow through the spacing between a pair of HGAs (mainstream) the state of inner track following get from the research (Hayato Shimizu et al., 2003) under resemble various conditions Most of the data reported in this paper information can also be used to further study the vibrations of head stack assembly (HSA) and to develop the finite element model of HGA.

---

*Department of Mechanical Engineering, Faculty of Engineering, Thammasart University, 99, Moo 18 Klong Luang, Pathumthani, 12120.*

*\*corresponding author; e-mail: jthira@engr.tu.ac.th*

## Finite Element Model

Finite element model of HGA in 3.5-in HDD was created using the commercially available finite element package, ANSYS version 10.(Eric et al., 2003) The overall model includes base plate, hinge, load arm and gimbals. The overall FE model is shown before boundary condition in Figure 1. A combination of 20 Node quadratic hexahedron (Solid186) in one element. The whole FE model includes elements 27142 solid elements and 12674 surface contact (Gu et al., 2006) base plate, hinge, load arm, and gimbals are made of stainless steel The FEA model's total number of degrees of freedom was approximately 105,356.

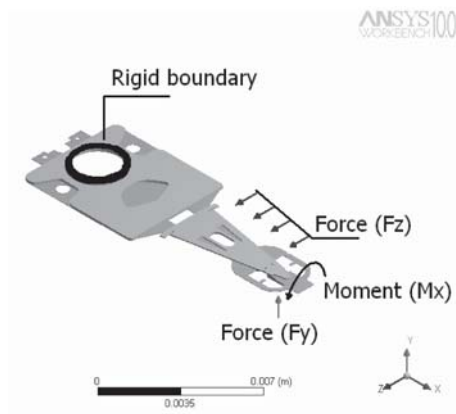

Figure 1. The overall FE model.

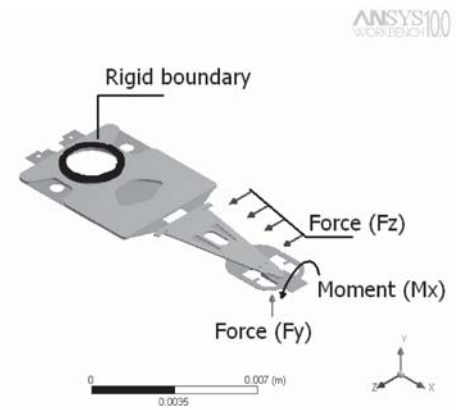

Figure 2. Environments model of HGA

The model used for the simulations show in Figure 2 rigid boundary and displacement of head slider Y direction form airflow on disk platter 5 to  $10e-6$  mm. The aerodynamic force exciting (i.e.,  $F_z = 1e-3N$ ,  $F_y = 1.5e-3N$ ,  $M_x = 2e-3N$ ) (Hayato Shimizu et al., 2003)

The finite element solver used, ANSYS, is a harmonic response mode superposition and mode-frequency analysis slover variable frequency from 500 to 15000 Hz and using three mode

From this point of view, it is preferable to design the system so that the resonance frequency of the head gimbal assembly is as high as possible. Figure 3 and Figure 4 show the analytical results both frequency response function (FRF) and the resonance mode of the commercial HGA system using the finite element analysis (FEA).

1) First bending mode. This is a bending mode induced by fixing the head slider with a base plat on the tip portion of the load arm, while the head slider is above the disk surface. The first bending mode influences the head positioning performance (accuracy) in normal read/write operations. The resonance frequency of the first bending mode is estimated to be 4.83 kHz in the commercial HGA.

2) First bending and gimbal torsion mode. This is the bending mode resemble with First bending mode only but the gimbal torsion happen at the same time first bending mode head slider to jump from the disk surface. The higher the resonance frequency of the first bending and gimbal torsion mode is estimated to be 7.73 kHz in the commercial HGA.

3) First torsion mode: This is the first torsion mode of the load arm. The resonance frequency of the first torsion mode is 10.59 kHz, which is also high enough for the practical control band of the system. (Hideki Kuwajima et al. 2006.)

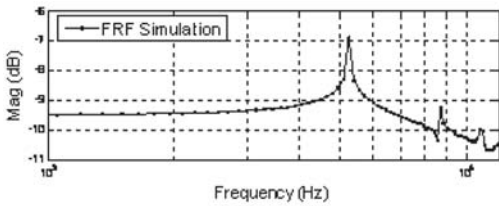

**Figure 3.** Frequency response function (FRF) from simulation

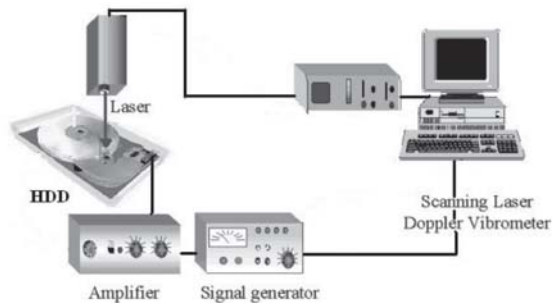

**Figure 4.** Mode shape of HGA vibration from simulation

### Experimental Results

Figure 5 shows the experimental setup. The specimen used in the experiments is a 3.5-in HDD rotating speed of disk platter 7200 rpm test on general operation system HDD. By exciting spindle motor and voice coil motor (VCM). The modes of the HGA were measured experimentally using a scanning laser Doppler vibrometer (LDV) the basic LDV transducer is a device which is capable of detecting the instantaneous velocity of the surface of a structure. The velocity measurement is made by directing a beam of laser light at the target point and measuring the Doppler shifted wavelength of the reflected light which is returned from the moving surface, using an interferometer. The measurement made is of the velocity of the target point along the line of the laser beam.(Ewins,1984 )

From Experimental setup model starting from signal exciting from signal generator excite the spindle motor and VCM after that signal of measurement from rank 500 to 15000 Hz send to dynamic signal analyzer (DSC) for at will seek Frequency response function. For measurement point show in Figure 6 scanning LDV automatic scan measure all point on surface.



**Figure 5.** Experimental setup model

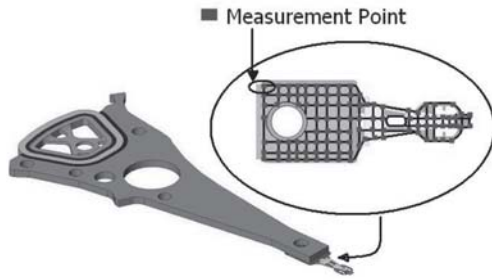

Figure 6. Measurement point of scanning LDV

Results of experimental display frequency response function show in Figure 7 and mode shape of HGA in Figure 8 results of experimental were used to verify the finite elements model.

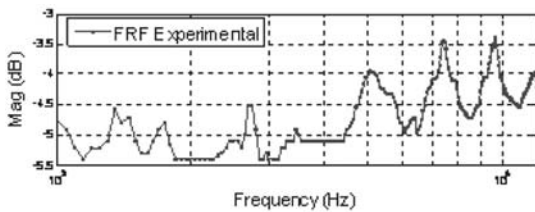

Figure 7. Frequency response function (FRF) from experimental

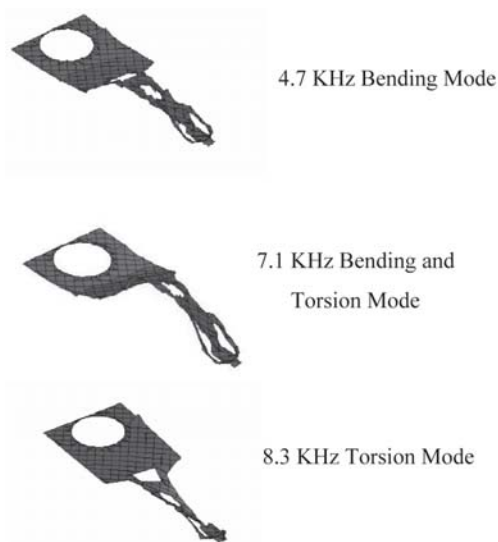

Figure 8. Mode shape of HGA vibration from experiment

Table 1. Resonance frequency of hga this experimental analysis was done by using scanning ldv measurement fea was done by using ansys workbench 10.0

Mode no.	FEA (Hz)	Exp (Hz)	Mode description	Ratio
1	4,837	4,938	First Bending	0.98
2	7,736	7,375	First Bending &Gimbal Torsion	1.05
3	10,595	9,750	First Torsion	1.09

**Conclusion**

The structural finite element model of the HGA in HDD, show in Figure 1, gives results for forces moments and Various Conditions applied to the HGA. A modal analysis of our model was performed and compared with experimental results. The results of the modal analysis are show in table I. We observe good agreement between the measured modes and the results of the finite element model. Most of the data reported in this paper information can also be used to further study the vibrations of head stack assembly (HSA) and to develop the finite element model of HGA.

**Acknowledgment**

The authors appreciate the cooperation and support of Seagate Technology (Thailand) during this research project. and also be appreciative to NECTEC for giving us this scholarship with contact number HDD 08-002M.

## References

- Eric M. Jayson, Paul W. Smith, and Frank E. Talke, 2003. "Shock Modeling of the Head-Media Interface in an Operational Hard Disk Drive," *IEEE Trans Magn.*, vol. 39, NO. 5, pp. 2429-2432, Sep.
- Ewins, D. J., 1984. *Modal Testing: Theory and Practice*. Hertfordshire, U.K.: Research Studies Press.
- Gu, B., Shu, D. W., Luo, J. and Shi, B. J., 2006. "FEA Simulation of Linear and Rotary Drop Test for Small Form Factor HDD," International Conference on Mechatronics and Automation, June 25 - 28, Luoyang, China.
- Hayato Shimizu, Toshihiko Shimizu, Mikio Tokuyama, Hiromitu Masuda, and Shigeo Nakamura, 2003. "Numerical Simulation of Positioning Error Caused by Air-Flow-Induced Vibration of Head Gimbals Assembly in Hard Disk Drive," *IEEE Trans Magn.*, vol. 39, No. 2 pp. 806-811, Mar.
- Hideki Kuwajima, Hiromi Kita, Hideyuki Hashi, Makoto Miyamoto, Yoshihiro Ueno, Tatsuhiko Inagaki, and Kaoru Matsuoka, 2006. "Development of Balanced-Type High Shock Suspension for 0.85-in Hard Disk Drive," *IEEE Trans Magn.*, vol. 42, NO. 2, pp. 255-260, Feb.
- Shigeo Nakamura, Ryouhei Aduma, Haruhide Takahashi, Kousaku Wakatsuki, and Shinobu Hagiya, 2005. "Flow-Induced Vibration of a Head Gimbal Assembly Under Various Conditions," *IEEE Trans Magn.*, vol. 41, NO. 2, pp. 769-773, Feb.

