

## Air Flow Simulation of 1.8 in Hard Disk Drive

Presented in 1<sup>st</sup> Data Storage Technology Conference (DST-CON 2008)

Sikarin Jintranun, Kiatfa Tangchaichit\*

---

### Abstract

The simulation model is constructed base on precisely actual dimension of current 1.8-in hard disk drive in the market with 3600 rpm rotation speed. Investigation of static pressure, velocity and flow behavior have been performed among actuator arm position of inner diameter (ID), middle diameter (MD) and outer diameter (OD) using RNG  $k$ -epsilon turbulent model. The numerical results shown how the air is brought inward to the centre of rotating disk and how the air is thrown outward toward disk edge. At the different actuator arm position, the static pressure, velocity and flow behavior are different. For instance, the pressure profile acting on the media forms the arm like profile when actuator is at ID and the pressure acting on media decrease when the actuator arm is at OD, the air flows along Head Gimbal Assembly (HGA) axis when the actuator is at OD and flows across HGA axis at ID, dispersion of the air due to the ramp load emerged into rotating disk region is also different when the actuator is at different position. These results help to predict the vibration of the actuator arm and the performance of recirculation filtering.

### Introduction

The emergence of 1.8-in hard disc drive in the consumer electronic device has pushed the usage of this new form of hard disk drive. At the same time, the hard disc manufacturing continues to enhance the capacity and the speed of hard disk drive. One of the most concerns is Track Miss Registration (TMR) which is caused by air flow in the hard disk drive, this concern still remains in this new form factor. Another concern is the performance of recirculation filtering which is used to filter various size of particles in the hard disk drive.

Investigation of airflow in HDD reported in recent year were studies of 2.5-in, 3.5-in and 1-in HDD (Suriadi et al., 2006; Albert Tan Chok Shion et al, 2006; Hayato Shimizu et al, 2000). Some of extended studies such as airflow induces vibration in 3.5 HDD (Albert Tan Chok Shion et al, 2006) and particle trajectory in HDD were reported. In this study, the author focuses on 1.8-in HDD available in the market with the rotational speed 3600 rpm, thus the Reynolds number based on the disk tip radius is around  $12.6 \times 10^3$ . This paper describes the airflow investigation using RNG  $k$ - $\epsilon$  turbulent model which is the most appropriate and economical turbulent model (Song et al.,) for HDD.

---

Department of Mechanical Engineering, Khon Kaen University, Khon Kaen, Thailand

Tel: 0-4320-2815 ext.151; Fax: 0-4320-2849

\*corresponding author; e-mail: kiatfa@kku.ac.th

**Numerical model**

The 3-D numerical model as shown in the Figure.1 is constructed base on actual 1.8-in hard disk drive inside the consumer products available in the market. The finite element methodology is used to carry out the simulation, 1.2 millions tetrahedral elements are used for all volume meshing. The Reynolds number based on disk tip radius is  $Re=\omega r^2/\nu=12.6 \times 10^3$  where  $w$  is the angular disk velocity ,  $r$  is disk radius and  $u$  is the kinematic viscosity. The steady state simulation

using RNG  $k-\epsilon$  turbulent model is preferred in this study due to lesser time consuming when compared to the Reynolds Stress Model (RSM) (Song et al.,). Also, the RNG  $k-\epsilon$  turbulent model give more accuracy compared to the standard  $k-\epsilon$  (Song et al.,). Hence, the RNG  $k-\epsilon$  turbulent model employed in this study is robust and provides a general trend of the air flow inside the 1.8 in HDD with an acceptable calculation time.

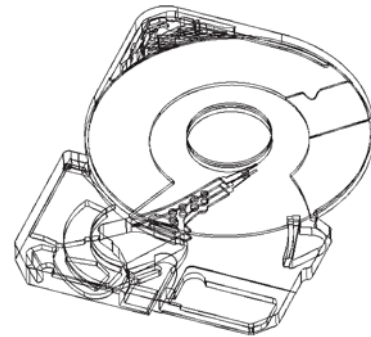
The models are constructed in order to investigate the air flow when the actuator arm functions at different position ID MD and OD. Figure 2 shown the schematic views of 1.8-in HDD when the actuator arm is at ID, MD and OD.

**Results and Discussion**

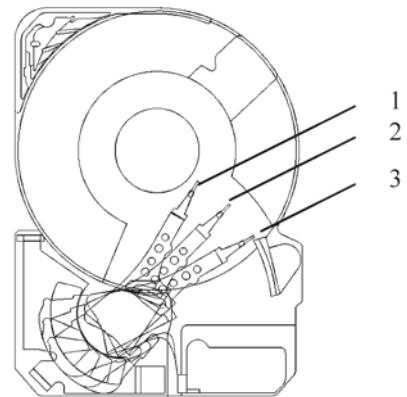
Simulation results provide many different flow variables values (e.g. static pressure, velocity). To study flow pattern in the hard disk drive, the velocity and static pressure are the main variables to analyze.

**A. Static Pressure Study in Hard Disk Drive**

At the media surface, the comparison of pressure acting on the media surface at each arm position as shown in Figure 3. At ID ,we observed arm likes

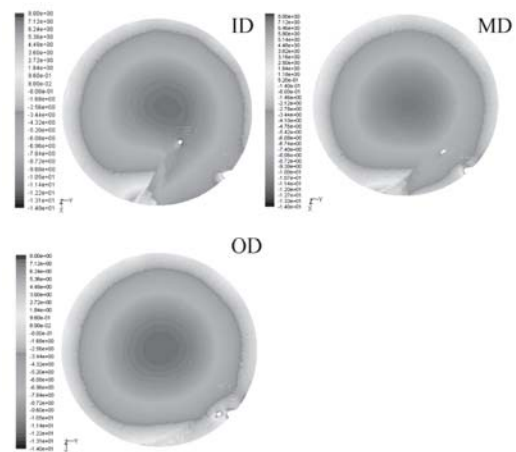


**Figure 1.** 3-D model of 1.8-in HDD available in the market.



1- Actuator arm at ID; 2-Actuator arm at MD;3- Actuator arm at OD

**Figure 2.** Schematic view of 1.8-in HDD when the actuator arm is at ID,MD and OD.



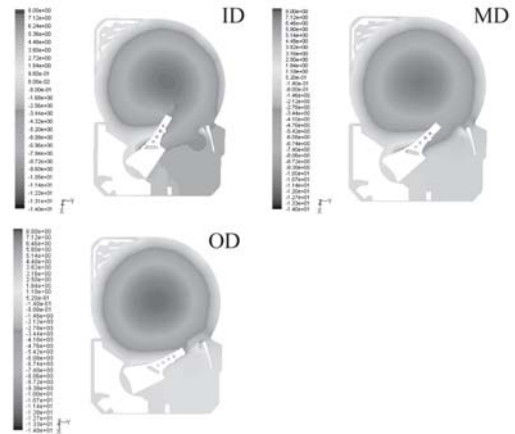
**Figure 3.** Contour plot of static pressure on media surface when the actuator arm is at ID, MD and OD

profile of static pressure on the media, the highest pressure is close the outside radius of media. The arm like profile of static pressure seems to be reduced at ID and OD position respectively. Instead, the pressure acting on leading edge of slider is higher at OD position. The maximum and minimum pressure observed in the model is around 18.4 pascal and -14.6 pascal respectively.

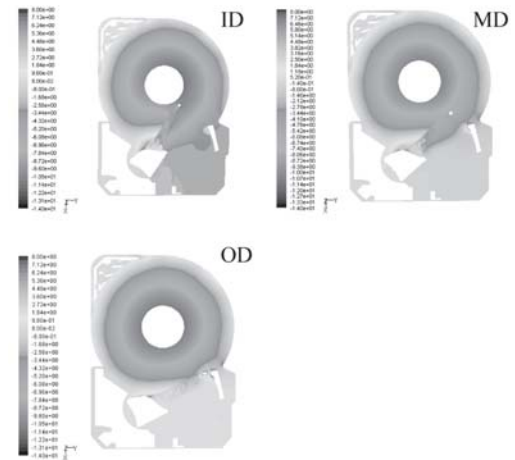
We observed the similar thing for all actuator arm positions ID, MD and OD in that the negative pressure is at the centre of media. The pressure increased relatively with the increasing of media radius. Also the concentrated pressure is observed the rim of the media where the ramp load is located as seen at the bottom left of the picture. The phenomenon is caused by the presence of the ramp load structure emerging into the rotating region.

At X-Y plan of  $z = -0.5$  mm from the top cover, surface which is cut through arm 2, as shown in Figure 4 , simulation results shown higher pressure at upstream region of actuator arm especially when the actuator arm is at ID position since air flow has been obstructed by actuator arm. This effect is decreasing when head move out to MD and OD respectively.

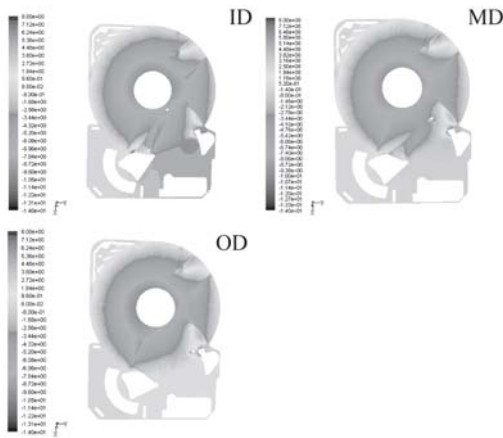
At X-Y plan of  $z = -2$  mm from the top cover, the surface which is cut through slider of arm 1, as shown in Figure 6 , the impact from base deck geometry to the pressure is more obvious, we clearly see pressure pattern follows to base deck geometry. Again, higher pressure acting on upstream side of slider when head is at OD position.



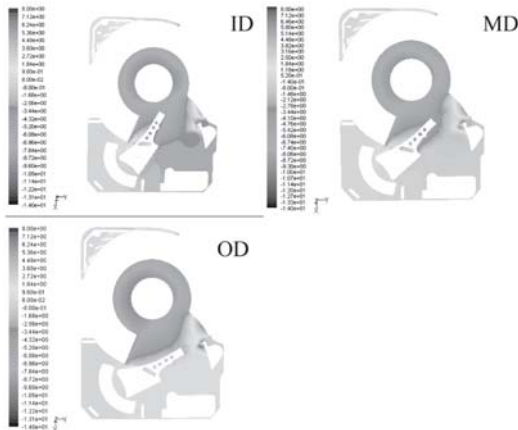
**Figure 4.** Contour plot of static pressure plot of X-Y plan of  $Z = -0.5$  mm from the top when the actuator arm is at ID, MD and OD



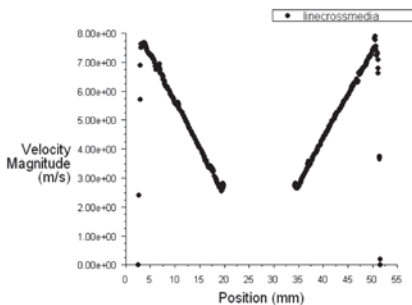
**Figure 5.** Contour plot of static pressure plot of X-Y plan of  $Z = -0.9$  mm from the top when the actuator arm is at ID, MD and OD



**Figure 6.** Contour plot of Static pressure plot of X-Y plan at Z = -2.0 mm from the top when the actuator arm is at ID, MD and OD



**Figure 7.** Contour plot of static pressure plot of X-Y plan at Z = -2.5 mm from the top when the actuator arm is at ID, MD and OD



**Figure 8.** Plot of velocity magnitude cross the media

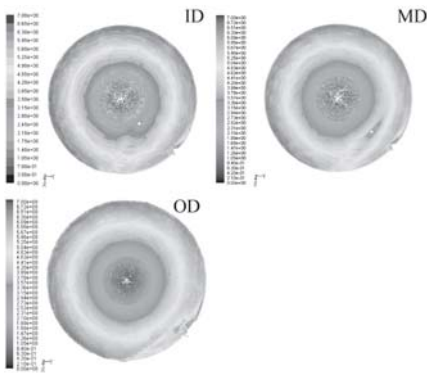
**B. Velocity Study in Hard Disk Drive**

The velocity of the air close to the disk surface shown strong relationship with the linear velocity which increase corresponds to increasing of disk radius regarding the formula  $v = \omega r$ , see in Figure8.

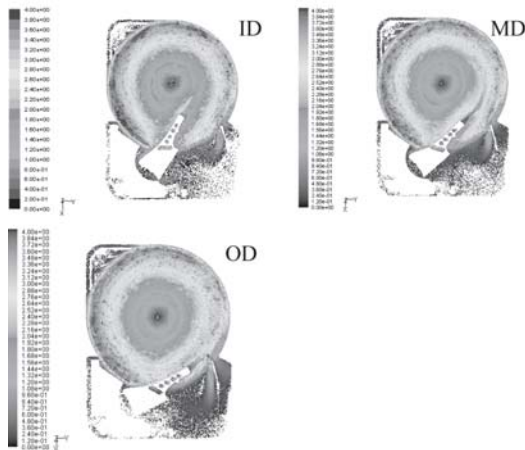
The air is obstructed by the slider inducing low velocity at the both upstream and downstream of slider region. The presence of the ramp load structure emerging to the rotating disk region as seen in lower left corner of the disk has dispersed the wind direction. See Figure9

At level X-Y plan of  $z = 0.5$ , the surface which is cut through the arm 2, the air flow is obviously obstructed by the actuator arm when the actuator arm is at ID, the air velocity is reduced at both upstream and downstream of the actuator arm but the lower air velocity at downstream region represented in blue color close to the arm tip. The wind obstruction is reduced when the actuator arm move to MD and OD respectively, the flow pattern looks as close as its of spinning disk with out the actuator arm when the actuator arm is at extreme OD.

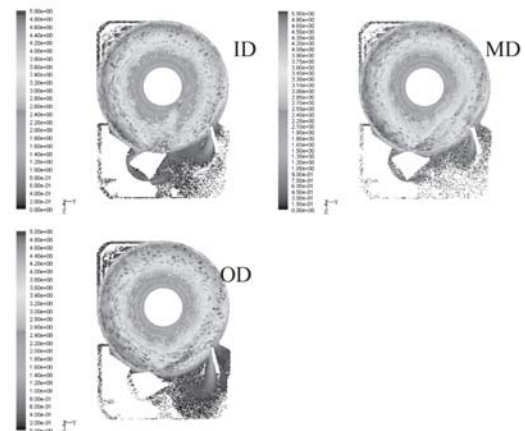
The results also show the impact of the ramp load structure which emerge into the rotating disk region, the air in the rotating disk region has been thrown downward when it hit the ramp load structure. When the actuator is at OD, the velocity of the air at the outer radius is maximized, the impact of this obstruction is more obvious than when the actuator arm is at MD or ID. However, the air which is thrown downward by ramp load structure will be evacuated back into the rotating disk region eventually, see Figure9,10 and 11. This phenomenon created the eddy at the bottom left outside the rotating disk, the more OD actuator is the bigger eddy diameter.



**Figure 9 .** Vector plot of velocity plot on media surface when the actuator arm is at ID, MD and OD

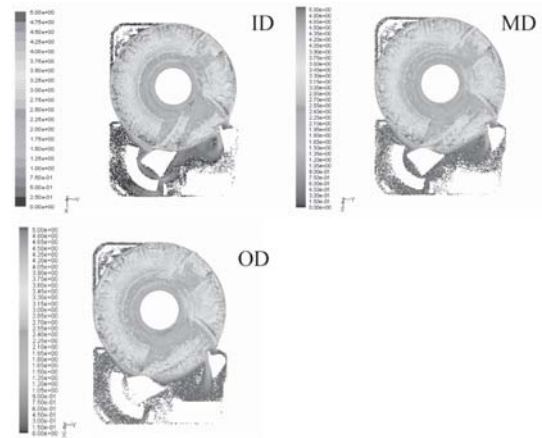


**Figure 10.** Vector plot of the air velocity of X-Y plan at Z = -0.5 mm from the top when the actuator arm is at ID, MD and OD

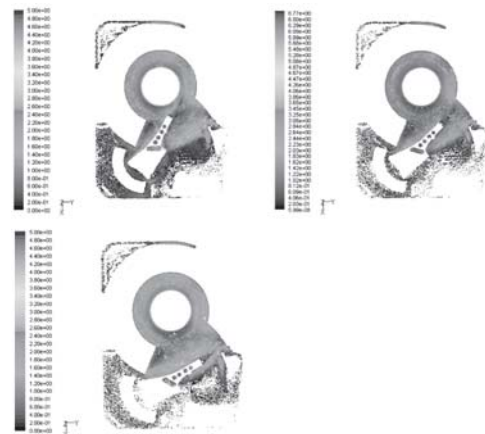


**Figure 11.** Vector plot of the air velocity of X-Y plan at Z = -0.9 mm from the top when the actuator arm is at ID, MD and OD

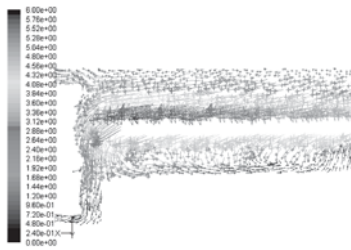
At  $z = -2\text{mm}$ , we still see impact of base deck geometry to the velocity as well as at  $z = -2.5\text{mm}$ . We observed higher air velocity at the shallower region than the air velocity at the deeper region. At this  $z$ -level, we still see the same flow pattern which is impacted by the ramp load same as previous  $z$ -level.



**Figure 12.** Vector plot of the air velocity of X-Y plan at Z = -2.0 mm from the top when the actuator arm is at ID, MD and OD



**Figure13.** Vector plot of the air velocity of X-Y plan at Z = -2.5 mm from the top when the actuator arm is at ID, MD and OD



**Figure 14.** Velocity plot of Z-X plan at the middle of HDD shown the air velocity above the rotating disk is higher than below the rotating disk.

### C. Study of Air Flow pattern

The flow pattern in 1.8 in HDD resulting from the numerical model shown the air flow with the high velocity follow the solid body rotation (media) some of the air has been thrown outside the rotating disk and slowly move along the recirculation filter before it is evacuated back to the rotating disk region. When the air reach to actuator arm, it will be thrown out from the left hand side of HDD. Then the air move slowly pass through the complex geometry of HSA and Voice Coil Magnet, Flex and PCC connector. Eventually, air will be evacuated into the rotating disk region again at the right and side of HDD at the region close to ramp load area.

The air in rotating disk region flow with higher velocity the maximum velocity is the the OD region, the numerical results shown the velocity of the air above the disk surface is higher than the air below disk surface. The different of the velocity between the upper and lower portion of the rotating disk due to non-symmetrical between the volume above and below the rotating disk. See in Figure14

### Conclusion

The steady state air flow inside 1.8 in HDD has been simulated using RNG  $k-\varepsilon$  turbulent model which give more accurate results than standard  $k-\varepsilon$  turbulent model while consume lesser time than RSM.

The numerical results shown greater value of pressure acting on actuator arm body when the actuator arm is at ID especially at the upstream region of the actuator as well as pressure acting on the media. In opposite, the pressure at slider increase when actuator arm move from ID to OD.

The velocity in the rotating disk area increase linearly along the disk surface from ID to OD. The air is obstructed by the actuator arm especially when the actuator arm is at ID. The ramp load emerging into rotating disk area has changed the direction of the air to move downward before it is sucked back into the rotating region, the more actuator arm move to OD the greater value of velocity of the air which is thrown downward. All these observation may help to estimate the occurring of vibration and particle trajectory in HDD.

### References

- Albert Tan Chok Shiong, Maria, Anastasia Suriadi and Zhang Qide, 2006. Studies on Air Flow Induced Vibration in a Simplified Hard Disk Drive using LES. Magnetic and Recording asia pacific.
- Hayato Shimizu, Mikio Tokuyama, Satomitsu Imai, Shigeo Nakamura, and Kazuo Sakai, 2000. Study of Aerodynamic Characteristics in Hard Disk Drives by Numerical Simulation. IEEE .
- Song, H., Damodaran, M. and Quock, Ng Y., Simulation of Flow Field and Particle Trajectories in Hard Disk Drive Enclosure.
- Suriadi, M.A., Tan, C.S., Zhang, Q.D., Yip, T.H., Sundaravivelu, K., 2006. Numerical investigation of airflow inside a 1-in hard disk drive, Sciencedirect March

